

VISOR® V20 Allround

Advanced vision sensor Professional for complex inspection tasks, 12 mm



PRODUCT HIGHLIGHTS

- All evaluations ("Detectors") of object sensor and code reader united in one device
- Highly accurate evaluation via 1.3 mega-pixel chip
- Real-world engineering units and robot coordinates at a mouse click
- Precise determination of X/Y position, orientation and tracking
- Detection of differences in height in the pseudo height image with multishot technology
- User-friendly configuration and viewer software with graded user rights and online help

Optical data		Functions	
Resolution	1280 × 1024 pixels	Number of jobs / detectors	max. 255 / max. 255
CMOS	1/1.8", monochrome	Detectors	Contour; pattern comparison, calliper; BLOB, contrast, brightness, grey level, Data code, Bar code, OCR
Integrated lens, focal length	12 mm, adjustable focal position	Properties	Position tracking: X/Y and orientation; pattern comparison / contour: teach-in and detection of patterns and contours; calliper: distance between edges; BLOB, grey threshold, brightness: evaluation of brightness; contrast: evaluation of contrast; bar code: reading 1D bar codes, EAN, UPC, RSS, 2/5 Interleaved, 2/5 Industrial, code 32, code 39, code 93, code 128, GS1, pharm code, codabar; data code: reading 2D codes: ECC200, QR code, PDF 417; OCR
Adjustment range	30 mm to infinity	Typical cycle times ²	Typ. 20 ms pattern comparison Typ. 30 ms contour Typ. 8 ms calliper Typ. 30 ms BLOB Typ. 2 ms brightness Typ. 2 ms contrast Typ. 2 ms grey threshold typ. 30 ms bar code typ. 40 ms data code typ. 15 ms per character OCR
Integrated illumination	White, red, infrared LEDs		
Minimum field of view, X × Y	16 × 13 mm ²		
Electrical data		Mechanical data	
Operating voltage, +U _b	18 ... 26.4V DC ¹	Dimensions	65 × 45 × 45 mm (without plug)
Current consumption (without illumination and I/O)	≤ 120 mA	Enclosure rating	IP 67
Current consumption (without I/O)	≤ 200 mA	Material, housing	Aluminium, plastic
Protective circuits	Reverse-polarity protection, U _b / short-circuit protection of all outputs	Material, front screen	Plastic
Power On Delay	Ca. 13 s after Power on	Ambient temperature: operation	0 ... +50° C ³
Outputs	PNP / NPN (switchable)	Ambient temperature: storage	-20 ... +60° C ³
Max. output current (per output)	50 mA, 100 mA (pin 12)	Weight	Ca. 160 g
Inputs	PNP/NPN High > U _b -1V, Low < 3V	Plug connections	Supply and I/O M12, 12-pin Ethernet M12, 4-pin Data M12, 5-pin
Input resistance	> 20 kOhm	Vibration and impact resistance	EN 60947-5-2
Encoder input	High > 4V		
Interfaces	Ethernet (LAN), RS422, RS232, EtherNet/IP, PROFINET, SensoWeb		
Inputs/outputs	2 inputs, 4 outputs, 4 selectable inputs/outputs		

¹ Max. ripple < 5V_{SS} ² with VGA-resolution (640 × 480 pixels) ³ 80 % air humidity, non-condensing

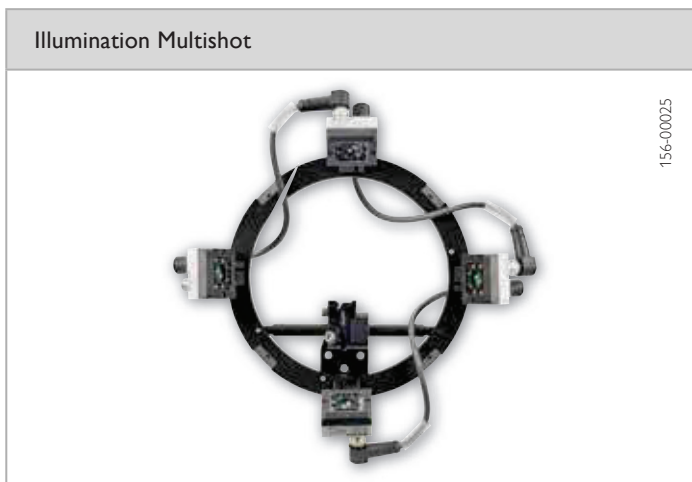
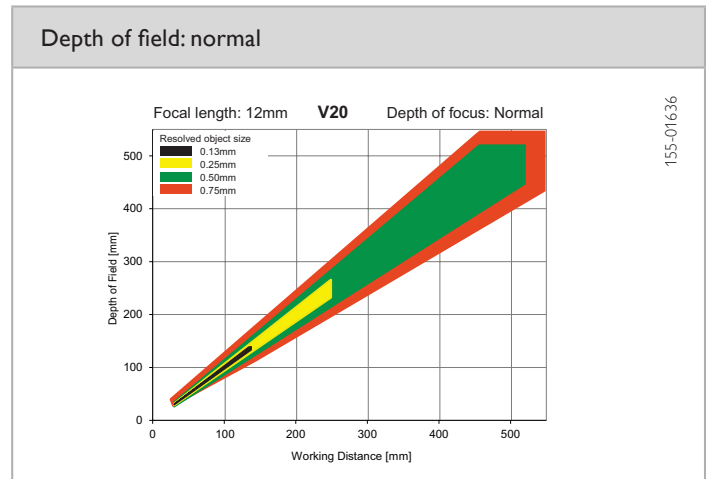
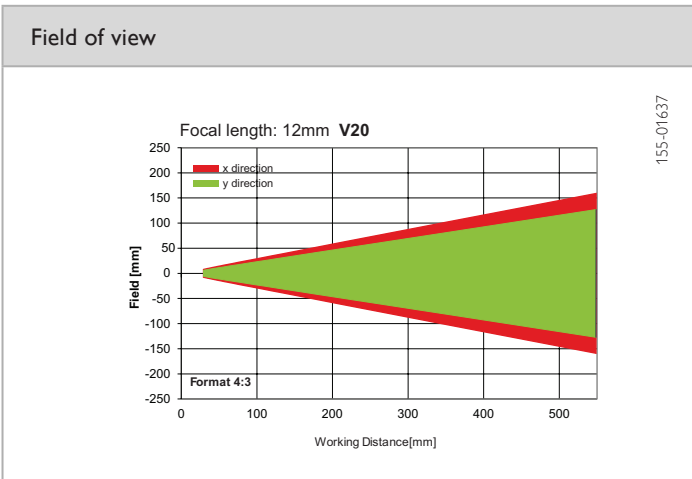
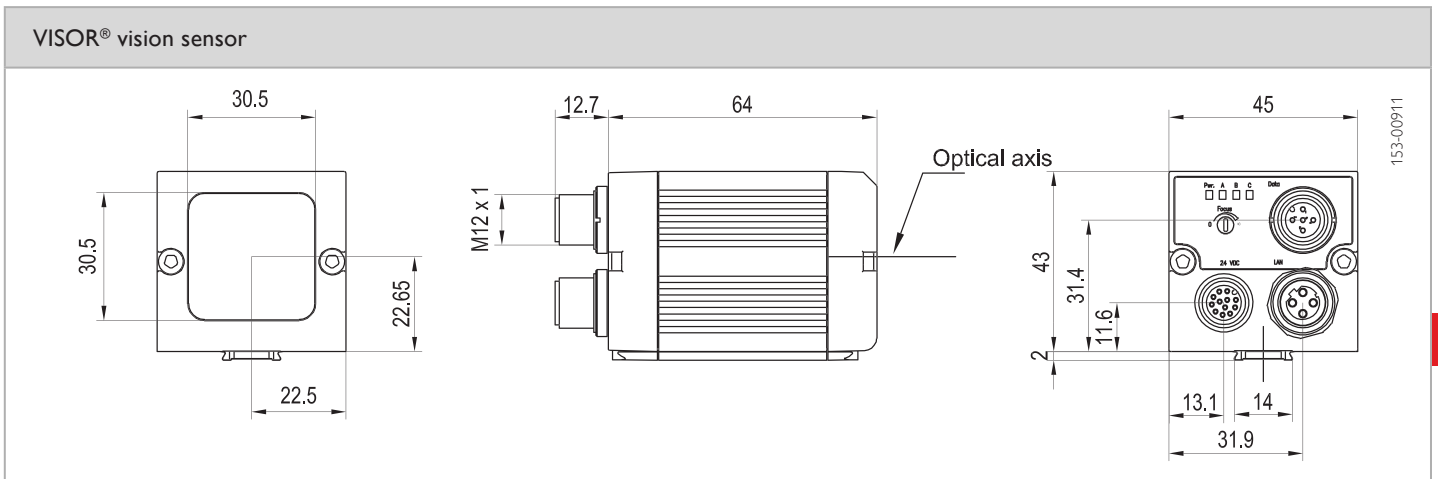

Illumination	Part number	Article number
White	LM300 WWK-24Q4-2L12	525-51158
Red	LM300 RWK-24Q4-2L12	525-51159
Infrared	LM300 IWK-24Q4-2L12	525-51160

Accessories

Connection cables	From Page A-38
Illumination	From Page A-30
Brackets	From Page A-14
Interface accessories	From Page A-42

Part number	Article number
V20-ALL-P2-W12	536-91040
V20-ALL-P2-R12	536-91041
V20-ALL-P2-I12	536-91042